



# POOL HEATER

# INSTALLATION, OPERATION AND MAINTENANCE

---

## **MODELS:**

### CE SERIES

12, 15 & 18kW  
208V, 240V, 480V

### CPH SERIES

24 & 30kW  
208V, 240V, 480V

### PHS SERIES

36, 45, 54 & 57kW  
208V, 240V, 480V

### **BEFORE YOU BEGIN**

CHECK ALL ELECTRICAL CONNECTIONS TO ALL COMPONENTS WITHIN THE HEATER FOR TIGHTNESS. CONNECTIONS CAN BECOME LOOSE DURING SHIPMENT AND HANDLING.

### **CAUTION**

THE ELECTRICAL INSTALLATION MUST BE IN ACCORDANCE WITH ARTICLE 680 OF THE NATIONAL ELECTRICAL CODE.

### **WARNING**

Only qualified personnel, as defined by National Electric Code Article 100, should install and maintain this equipment. Unauthorized alteration or improper maintenance of this unit may release the manufacturer from any warranty claims. The installation must be in accordance with the instructions in this manual and applicable local plumbing and electrical codes.

# IMPORTANT SAFETY INSTRUCTIONS

When using this electrical equipment, basic safety precautions should always be followed, including the following.

## 1) READ AND FOLLOW ALL INSTRUCTIONS.

2) To reduce the risk of injury.

- A) The water in a pool or tub should never exceed 104°F (40°C). A water temperature in excess of 104°F is considered unsafe for all persons. Lower water temperatures are recommended for extended use (exceeding 10-15 minutes) and for young children.
- B) Since excessive water temperatures have a high potential for causing fetal damage during the early months of pregnancy, pregnant or possibly pregnant women should limit pool or tub water temperatures to 100°F (38°C).
- C) Before entering a pool or tub, the user should measure the water temperature at several occupant locations using an accurate thermometer since the tolerance of water temperature-regulating devices may vary as much as  $\pm 5^{\circ}\text{F}$  ( $\pm 3^{\circ}\text{C}$ ).
- D) Alcohol, drugs or medications should not be used before or during pool or tub use since their use may lead to unconsciousness with the possibility of drowning.
- E) Obese persons and persons with a medical history of heart disease, low or high blood pressure, circulatory system problems, or diabetes should consult a physician before using a pool or tub.
- F) Persons using medication should consult a physician before using a pool or tub since some medication may induce drowsiness while other medication may affect heart rate, blood pressure, and circulation.

## 3) SAVE THESE INSTRUCTIONS.

### ---WARNING--- DANGER OF HYPERTHERMIA

Hyperthermia occurs when the internal temperature of the body reaches a level several degrees above the normal body temperature of 98.6°F. The symptoms of hyperthermia include dizziness, fainting, drowsiness, lethargy and an increase in the internal temperature of the body. The effects of hyperthermia include:

- a) Unawareness of impending hazard;
- b) Failure to perceive heat;
- c) Failure to recognize the need to exit pool or tub;
- d) Physical inability to exit pool or tub;
- e) Fetal damage in pregnant women;
- f) Unconsciousness resulting in a danger of drowning.

**WARNING---** The use of alcohol, drugs or medications can greatly increase the risk of fatal hyperthermia in pools and tubs.

## WARNING

Only qualified personnel, as defined by National Electric Code Article 100, should install and maintain this equipment. Unauthorized alteration or improper maintenance of this unit may release the manufacturer from any warranty claims. The installation must be in accordance with the instructions in this manual and applicable local plumbing and electrical codes.

## INTRODUCTION

This manual provides installation procedures, operating and maintenance instructions and a parts list for the Coates Pool Heater.

Your Coates Electric Swimming Pool Heater has been designed and engineered to provide you with the most progressive quality heating system possible. Its operation is efficient and pollution-free. Models are available for every size or make of pool.

To insure a long life of trouble-free service, your Coates Pool Heater should be carefully installed in accordance with the instructions given in this manual. Failure to do so may damage the pool heater and the pool equipment to which it is connected. Only qualified personnel should install and maintain this unit, and, of course, local plumbing and electrical codes have precedence over these instructions.

### 1.0 DESCRIPTION

The Coates Swimming Pool Heater consists of a heating tank with external enclosure, and the electrical heating and control system. In order to help maintain the heater in a satisfactory manner, a brief description of its components and their operation is included for the customer's convenience.

The pressure vessel and its enclosure comprise the main mechanical portion of the pool heater.

The pressure vessel, in conjunction with the flow switch and heating element are the only portions of this equipment in contact with the water.

The external enclosure is a sheet steel case totally enclosing the pressure vessel and electrical components. The enclosure is coated with a rust inhibiting, powder coat finish.

The electrical system, which is the heart of this unit, can be considered as three separate systems engineered to provide optimum use of energy. They are as follows:

(1) **The heating elements;** mounted on a four-bolt flange. There are 2, 3 or 4 elements.

(2) **The control system;** consists of the pilot switch, high limit thermostat, flow switch, temperature control, magnetic contactors, 240V transformer (480V units only) and sequencer (on some single phase units only). These controls are wired into a control circuit designed to control the temperature of the water leaving the heater. The high-limit thermostat is designed to open the control circuit and cut off the power in the event of excessive temperature.

A flow switch is built-in to prevent the pool heater from operating without water flow. The flow switch will activate at flow rates of 20 GPM or greater.

(3) **The main current-carrying components;** are the contactors and fuses. These are wired into circuits which carry the full amperage draw of the elements. The contactors open during a high temperature condition to de-energize the elements.

The element fuses in these units are rated at 60 Amps and have an interrupting capacity of 100,000 Amps rms. These fuses provide supplemental circuit protection for the internal wiring of the heater.

The heater has a temperature controller adjustable up to 104°F(40°C) and has one manual reset type high temperature limit thermostat set at 118°F (48°C).

## 2.0 LOCATION AND PLUMBING

### A. Installation: Location

Coates swimming pool heaters are quiet, do not expel exhaust fumes, and may be conveniently located in a shed or basement. Normal positioning of the pool heater should be in close proximity to the pool filtration system. Select a location conveniently close to incoming electrical service and where excessively long piping runs are not required.

#### Minimum clearance:

	PHS/CPH	CE
Front	36 (914)#	36 (914)#
Left	18 (457)	4 (102)
Right	*	4 (102)
Top	18 (457)	20 (508)
Back	6 (153)	*

\* Required clearance is based on plumbing configuration used.

# Refer to NEC Table 110.26 (A)(1)

- Dimensions: Inches (mm)

- Temperature control is located on the front side.

## B. Installation: Plumbing

Pipe the heater as shown in Figure 2 to the inlet and outlet openings on the right side. Connect the heater in line between the filter discharge and pool. The water line coming from the filter should be connected to the heater *inlet*, and the discharge line to the pool should be connected to the *outlet*. The pool will not heat properly unless it is plumbed correctly. If plastic pipe is used, it should be suitable for at least 120°F (49 °C).

A plumbing bypass around the pool heater is not necessary unless the flow rate through the heater exceeds 80 GPM. A minimum flow rate of 20 GPM is required. Lack of sufficient flow will not allow the flow switch to activate the heater.

It may be necessary, in larger Olympic-sized or public pools, to use two or more heaters to obtain sufficient KW capacity. If so, the heaters must be placed in parallel, so that each heater takes equal flow.

**DRAINAGE:** A method of draining water away from the heater and other equipment is to be provided. The heater should be flushed at the end of each swimming season. During flushing or service, water may spill and could cause damage to the floor or other equipment. A drain valve is to be installed in the INLET plumbing.

## 3.0 ELECTRICAL INSTALLATION

1. Check nameplate rating to insure the heater matches your electrical supply.
2. **CHECK ELECTRICAL CONNECTIONS TO ALL COMPONENTS** within the heater for tightness. These can become loose during shipment and handling.
3. Check components for any moisture, rust, or dust which may have accumulated during shipping, and clean or dry where necessary.

All pool heaters covered in this manual have integral thermostats, transformers, contactors and sequencers where required.

Wiring diagrams included show internal wiring and required field connections for various models. Consult your local electrical code for proper wire and conduit sizes, and other local requirements.

Do not connect the pool heater to, or operate at, a voltage other than the voltage rated on the nameplate.

Bring wires of adequate size from a fused disconnect switch or circuit breaker with an ampere rating of 125% of the ampere rating shown on heater nameplate. Refer to Table 1 for wire sizes. Connect power conductors to the power distribution block inside

the heater. All other internal connections are completed and tested at the factory.

Ground wires must be insulated copper conductor and the same size as supply wiring, but not less than #12 AWG.

**Table 1**

KW	WIRE SIZE: AWG			
	240V/1Ø	208V/3Ø	240V/3Ø	480V/3Ø
12	See pg 9	8	8	12
15		6	8	10
18		4	6	10
24		3	4	8
30		2	3	8
36	3/0	1	2	6
45	250MCM	2/0	1/0	4
54	350MCM	3/0	2/0	3
57	350MCM	3/0	2/0	3

Suggested size for insulated copper conductor wires. Based on 125% correction factor for wire with 75°C insulation.

## A. To Connect Pool Heater to Power Supply

The pool heaters with load ratings over 48 Amps have branch supplemental fusing already installed in the element circuitry; see wiring diagrams. To connect to the power supply, one needs only to protect the main supply lines, either with a circuit breaker or fused disconnect switch (Figure 1). Suggested wire sizes are shown in Table 1.

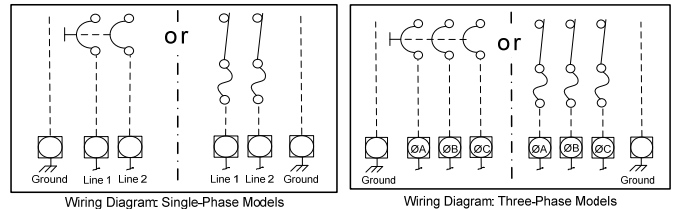

**Figure 1**

## B. Startup Procedure:

1. Make sure that the pump is on and that there is at least 20 GPM flow through the pool heater. The heating elements will fail prematurely if allowed to operate with insufficient water flow.
2. Check temperature control setting, also, examine wiring for loose connections, etc.
3. Turn on power at main disconnect switch.
4. Turn on pilot switch on pool heater.

If the high temperature manual reset high limit switch shuts off the heater, disconnect power at disconnect switch and determine the cause before resetting.

## 4.0 CONTROL PANEL

### A. INDICATOR LIGHTS

The control has three indicator lights and a lighted ON-OFF rocker switch. The lights are as follows:

STATUS LIGHTS	
LIGHT	DESCRIPTION (when Illuminated)
ON-OFF	Heater has power to control circuit.
RESET	High Temperature limit is OK.
FLOW	Sufficient water flow through heater.
ELEMENT	Heating elements are powered.

### B. DIGITAL THERMOSTAT CONTROL

For heaters equipped with a digital thermostat. The digital thermostat control which measures the temperature of the water as it enters the heater has a MENU button, up and down adjustment buttons, and an LED display. The desired water temperature (set point) is controllable between 40°F and 104°F (5°C and 40°C). The set point may differ from the actual water temperature at the pool or spa due to heat loss in the piping.

#### MENU:

The MENU button cycles through the three menu items: Measured Water Temperature (default), SET POINT and °F/°C.

#### ADJUSTING THE SET POINT:

Press one of the following buttons; MENU, ⤴ or ⤵. The display will momentarily blank and then the current set point will be displayed. Press the ⤴ or ⤵ button to change the set point. Hold the button down for rapid temperature changes.

The set point will be saved and the display will return to the measured temperature after two seconds of inactivity.

#### OPERATION:

In the measured temperature mode, the water temperature in the heater is displayed. The LED corresponding to the current temperature scale will be illuminated. If the heater is calling for heat the HEATING LED will be illuminated.

#### FAHRENHEIT TO CELCIUS:

Press the MENU button twice and the current temperature scale will be displayed ( F or C ). Press the ⤴ or ⤵ buttons to toggle between F and C.

The temperature scale will be saved and the display will return to the measured temperature after two seconds of inactivity.

#### ERROR CODE:

The display will read "Err" when it detects a problem with the temperature sensor. This can be caused by a faulty sensor or a loose connection between the sensor and the temperature controller.

## 5.0 MAINTENANCE

Element Inspection and Replacement:

1. Turn off power at main disconnect switch and turn off pump.
2. Drain pool heater.
3. Remove service access panel opposite inlet/outlet.
4. Disconnect element wires.
5. Remove the four (4) element flange retaining nuts and extract element.
6. Installation is the reverse of steps 1 through 5. (Reinstall element with new gasket)

When closing down the pool for any length of time, shut off the power at the main disconnect switch and drain the water from the system. Water must not be allowed to freeze in the heater, as this will cause severe damage.

#### Annual Cleaning:

Yearly, before winter, the pool heater should be drained and cleaned to remove any scale or sludge. More frequent cleaning may be required if pool water contains sediment or any amount of foreign matter.

1. Turn off heater at main disconnect switch.
2. Open drain valve.
3. Permit water to run until it is clear.
4. Close valve and restart normally.

# POOL HEATER PARTS LIST MODELS CE, CPH & PHS

ILLUSTRATION ITEM No.	COMPONENTS	HEATER MODEL No.																																												
		SINGLE PHASE — 240V				THREE PHASE — 208V				THREE PHASE — 240V				THREE PHASE — 480V																																
		12418CE	12418CPH	12418PHS	12418PHS	32018CE	32018CPH	32018PHS	32018PHS	32418CE	32418CPH	32418PHS	32418PHS	34818CE	34818CPH	34818PHS	34818PHS																													
	TOTAL KW PER HEATER	12	15	18	24	30	36	45	54	57	12	15	18	24	30	36	45	54	57	12	15	18	24	30	36	45	54	57	12	15	18	24	30	36	45	54	57									
	AMPERAGE AT FULL LOAD	51	64	77	102	128	153	191	225	238	34	42	50	67	84	101	126	150	158	30	37	45	59	74	89	111	130	137	15	19	22	29	37	44	55	65	69	2	2	2	2	2	2	2	2	2
	ELEMENTS PER HEATER	2	2	2	2	2	2	2	2	2	2	2	2	2	2	2	2	2	2	2	2	2	2	2	2	2	2	2	2	2	2	2	2	2	2	2	2									
18	FUSE, F-1, SC-60, 60A/480V																																													
3	FUSE, F-5, FNQ-R-1, 1A/600V																																													
4	FUSE, F-6, FNQ-R-1/2, 0.5A/600V																																													
6	FLOW SWITCH	1	1	1	1	1	1	1	1	1	1	1	1	1	1	1	1	1	1	1	1	1	1	1	1	1	1	1	1	1	1	1	1	1	1											
7	T5, XFMR 480V/240V-50VA																																													
8	TS-3 DIGITAL POOL STAT	1	1	1	1	1	1	1	1	1	1	1	1	1	1	1	1	1	1	1	1	1	1	1	1	1	1	1	1	1	1	1	1	1	1											
9	PL-1, 2 & 4, PILOT LIGHT, AMBER 120/240V	3	3	3	3	3	3	3	3	3	3	3	3	3	3	3	3	3	3	3	3	3	3	3	3	3	3	3	3	3	3	3	3	3	3											
9	PL-3, PILOT LIGHT, AMBER 480V																																													
10	RS-2 ROCKER SWITCH, LIGHTED 240V	1	1	1	1	1	1	1	1	1	1	1	1	1	1	1	1	1	1	1	1	1	1	1	1	1	1	1	1	1	1	1	1	1	1											
11	TS-1 HIGH TEMP. LIMIT	1	1	1	1	1	1	1	1	1	1	1	1	1	1	1	1	1	1	1	1	1	1	1	1	1	1	1	1	1	1	1	1	1	1											
12	ELEMENT, 6 KW, 208V																																													
12	ELEMENT, 9 KW, 208V																																													
12	ELEMENT, 12 KW, 208V																																													
12	ELEMENT, 15 KW, 208V																																													
12	ELEMENT, 6 KW, 240V	2	1																2	1																										
12	ELEMENT, 9 KW, 240V	1	2																1	2																										
12	ELEMENT, 12 KW, 240V																																													
12	ELEMENT, 15 KW, 240V																																													
12	ELEMENT, 6 KW, 480V																																													
12	ELEMENT, 9 KW, 480V																																													
12	ELEMENT, 12 KW, 480V																																													
12	ELEMENT, 15 KW, 480V																																													
13	ELEMENT GASKET	2	2	2	2	2	2	2	2	2	2	2	2	2	2	2	2	2	2	2	2	2	2	2	2	2	2	2	2	2	2	2	2	2	2											
14	RELAY, 30AMP, SPST, NO	1	1	1	1	1	1	1	1	1	1	1	1	1	1	1	1	1	1	1	1	1	1	1	1	1	1	1	1	1	1	1	1	1	1											
15	K-7 SEQUENCE TIMER 1-POLE																																													
17	CR-7 CONTACTOR 3P, 208/240V COIL	3	3	3	4	4	7	7	8	8	2	2	2	4	4	5	7	7	2	2	2	4	4	5	7	7	2	2	2	2	2	2	2	2	2											
16	CR-8 CONTACTOR 4P, 208/240V COIL																																													

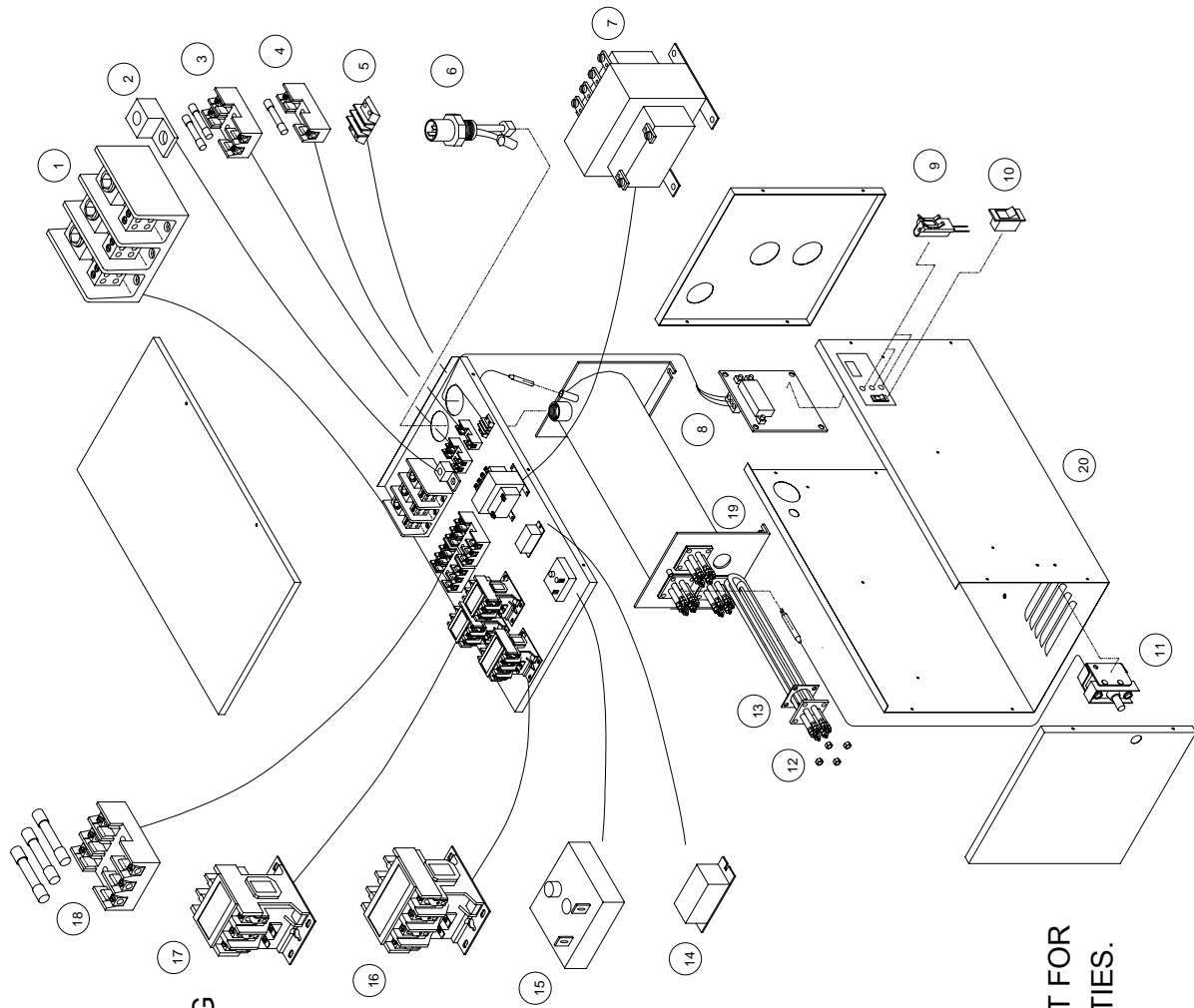

1. POWER DISTRIBUTION BLOCK
2. GROUND LUG
3. CONTROL TRANSFORMER PRIMARY FUSING
4. CONTROL TRANSFORMER SECONDARY FUSING
5. EXTERNAL CONTROL CONNECTION
6. FLOW SWITCH
7. CONTROL TRANSFORMER (WHEN REQUIRED)
8. TEMPERATURE CONTROL
9. PILOT LIGHTS - ELEMENT, FLOW, RESET
10. PILOT SWITCH, LIGHTED "ON/OFF"
11. TEMPERATURE LIMIT SWITCH
12. HEATING ELEMENT
13. HEATING ELEMENT GASKET
14. FLOW RELAY
15. SEQUENCE TIMER (WHEN REQUIRED)
16. CONTACTOR (4-POLE)
17. CONTACTOR (3-POLE)
18. HEATER CIRCUIT FUSING
19. VESSEL
20. ENCLOSURE

**NOTE:**  
 REFERENCE THE POOL HEATER PARTS LIST FOR  
 COMPONENT PART NUMBERS AND QUANTITIES.

# WATER CHEMISTRY

## PROTECTING YOUR COATES HEATER WITH PROPER WATER CHEMISTRY

Proper water balance is important to extending the life of your Coates Heater. While pH control is critical, the control of alkalinity and calcium hardness will protect against scaling and also help to prevent corrosion.

		ACID							ALKALINE									
HEATER CAN BE DAMAGED		CORROSIVE WATER							IDEAL RANGE	ALKALINE WATER							HEATER CAN BE DAMAGED	
		0	1	2	3	4	5	6		7	8	9	10	11	12	13		
									7.2-7.8									

The correct level of sanitizer, pH, total alkalinity and calcium hardness will vary, depending on the type of pool (plaster, fiberglass or vinyl) and the chemical content of the fill water. Water that is out of balance can damage your pool heater and void the warranty. This heater is not for use in salt water pools.

# PLUMBING CONNECTIONS

**\*\* NOTICE \*\***

NO PRESSURE RELIEF VALVE IS SHIPPED WITH THIS HEATER AND NONE IS REQUIRED PER UL STD 1261. DO NOT INSTALL SHUT OFF VALVE BETWEEN THE HEATER AND POOL OR SPA. A CHECK VALVE IS ACCEPTABLE AND IN ACCORDANCE TO UL STD 1261 REVISED JULY 1983.

**CAUTION**  
DO NOT INSTALL ANY SHUT-OFF VALVE ON DISCHARGE SIDE OF HEATER. A SWING CHECK VALVE IS PERMITTED.

Exception: If a 30 psi (2.1 Kg/cm<sup>2</sup>) pressure relief valve is installed between the heater and valve, the valve may be of the shut-off (ball or gate) type.

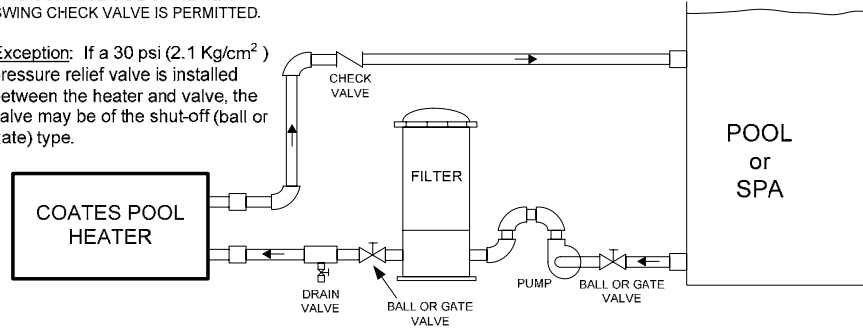

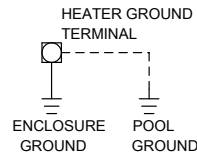
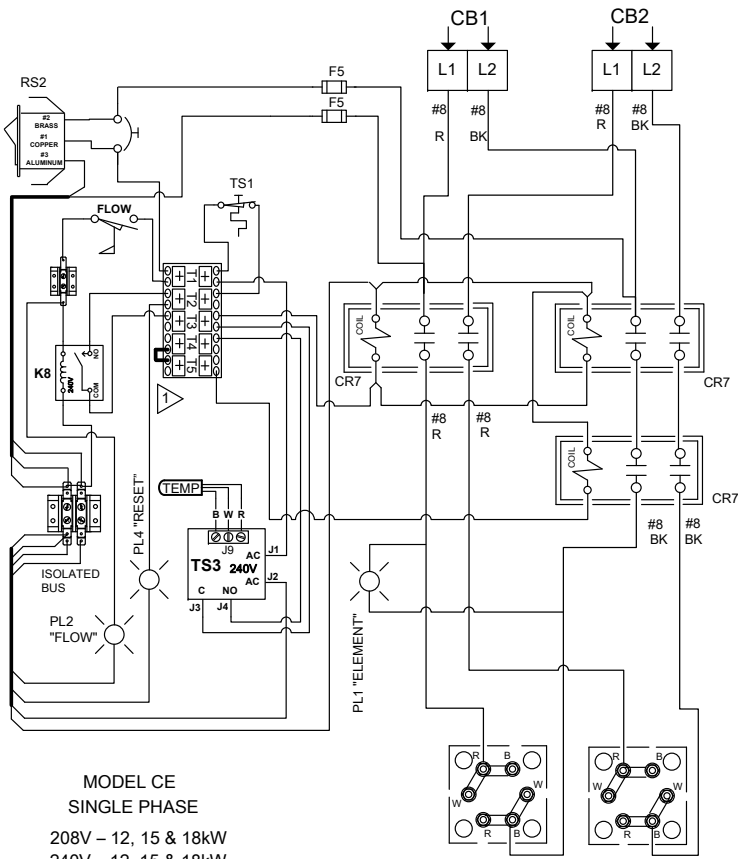

1. FACTORY JUMPER PROVIDED FOR CONNECTION TO CUSTOMER SUPPLIED AUXILIARY CONTROLS. REMOVE JUMPER AND CONNECT ONE SIDE OF CONTROL TO T4 AND ONE SIDE TO T5.
2. SEE INSTRUCTION MANUAL FOR COMPONENT IDENTIFICATION.
3. ALL WIRING TO BE 105°C INSULATED, MINIMUM. CONTROL CIRCUIT WIRING; 14 AWG. POWER CIRCUIT WIRING; AS NOTED.
4. LEGEND:  
R = RED  
BK = BLACK  
W = WHITE
5. HEATING ELEMENT QTY/RATING;  
12kW = 2 @ 6kW  
15kW = 1 @ 6kW & 1 @ 9kW  
18kW = 2 @ 9kW

Model #	kW	Voltage	Ph	Amps	copper AWG No.	Breaker Size
12412CE	12	240	1	50	10	35 (Qty 2)
12415CE	15	240	1	63	8	50 (Qty 2)
12418CE	18	240	1	75	8	50 (Qty 2)
12012CE	12	208	1	58	8	40 (Qty 2)
12015CE	15	208	1	72	6	60 (Qty 2)
12018CE	18	208	1	87	6	60 (Qty 2)

MODEL CE  
SINGLE PHASE

208V - 12, 15 & 18kW  
240V - 12, 15 & 18kW

1BC1218J

HEATING ELEMENTS

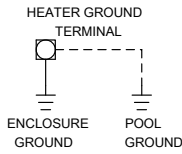
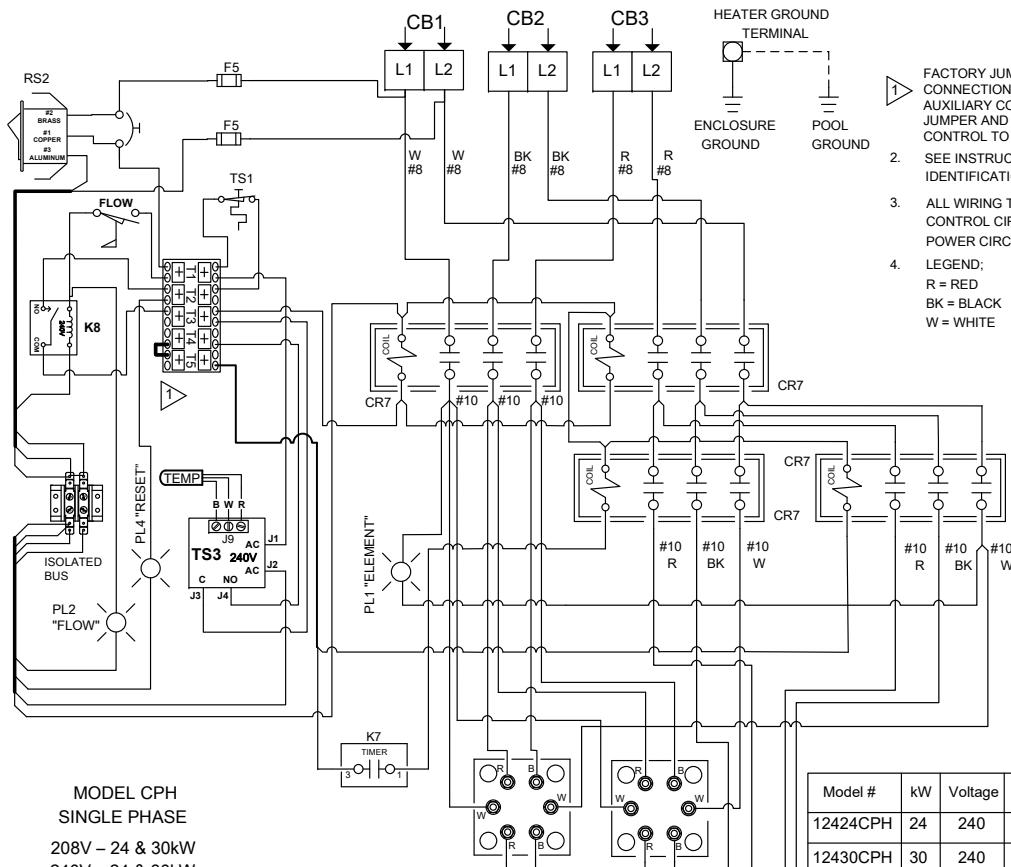

1. FACTORY JUMPER PROVIDED FOR CONNECTION TO CUSTOMER SUPPLIED AUXILIARY CONTROLS. REMOVE JUMPER AND CONNECT ONE SIDE OF CONTROL TO T4 AND ONE SIDE TO T5.
2. SEE INSTRUCTION MANUAL FOR COMPONENT IDENTIFICATION.
3. ALL WIRING TO BE 105°C INSULATED, MINIMUM. CONTROL CIRCUIT WIRING; 14 AWG. POWER CIRCUIT WIRING; AS NOTED.
4. LEGEND:  
R = RED  
BK = BLACK  
W = WHITE

Model #	kW	Voltage	Ph	Amps	copper AWG No.	Breaker Size
12424CPH	24	240	1	100	8	50 (Qty 3)
12430CPH	30	240	1	125	6	60 (Qty 3)
12024CPH	24	208	1	116	8	50 (Qty 3)
12030CPH	30	208	1	145	6	60 (Qty 3)

MODEL CPH  
SINGLE PHASE

208V - 24 & 30kW  
240V - 24 & 30kW

1BC2430L

HEATING ELEMENTS

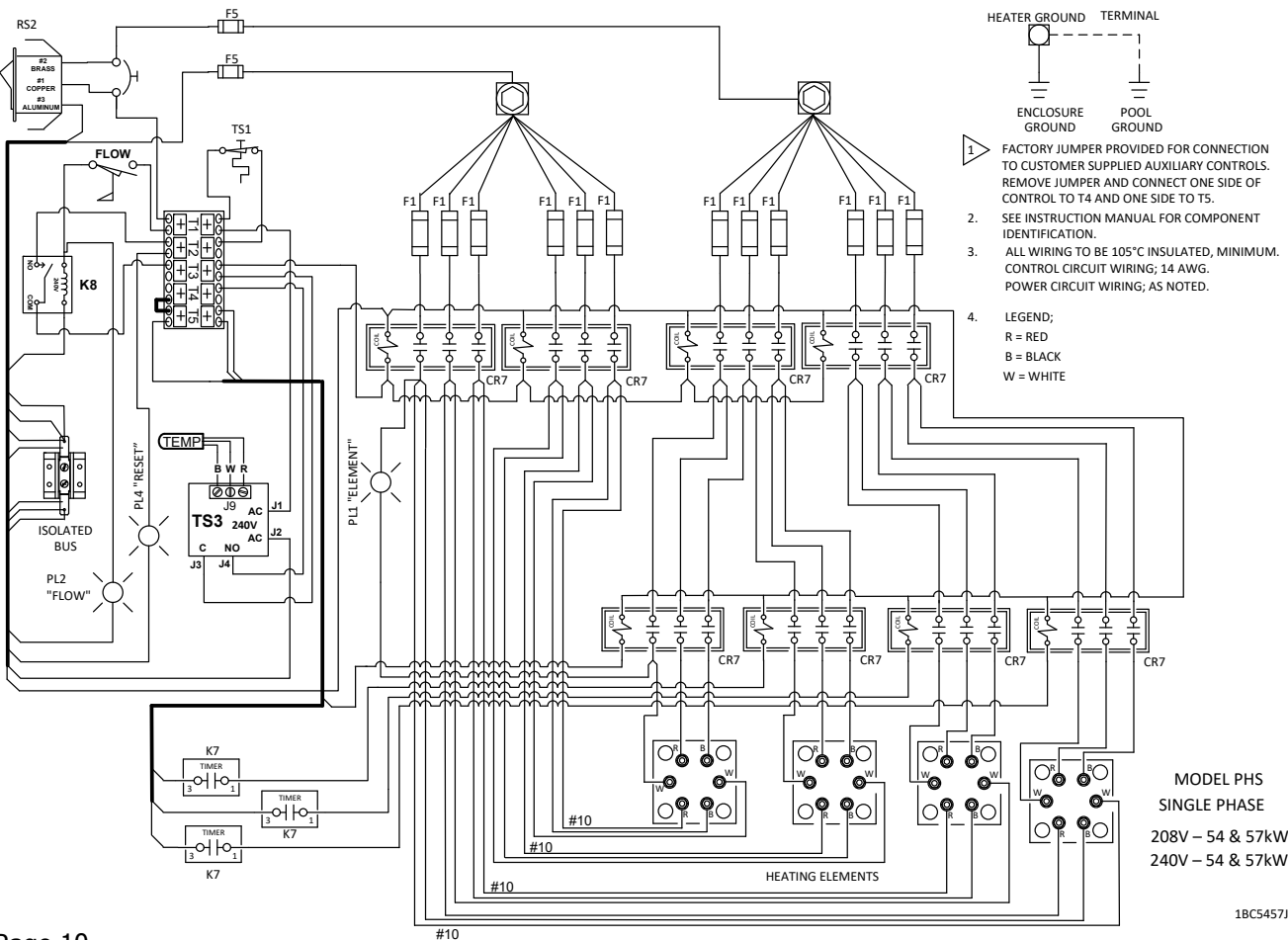
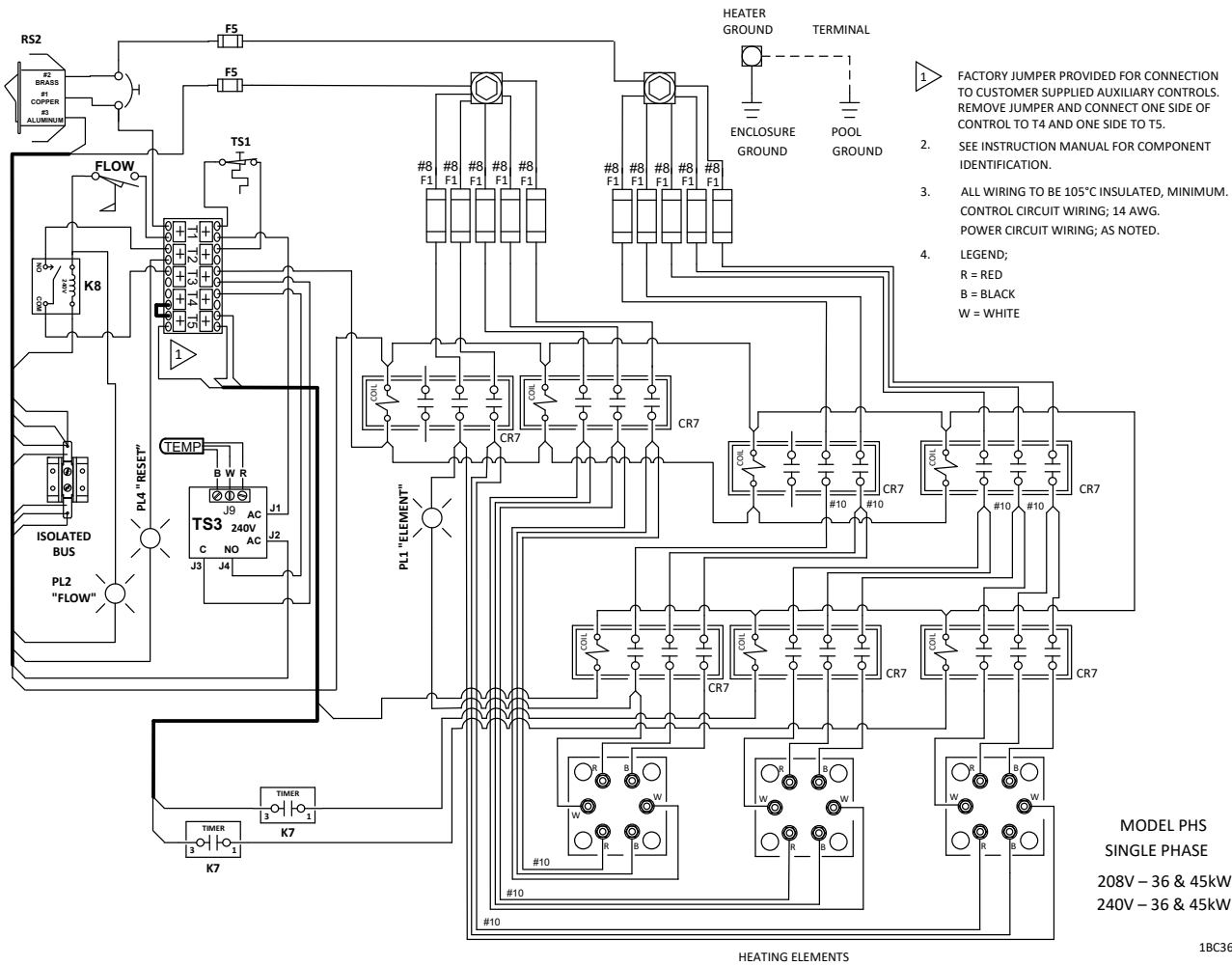

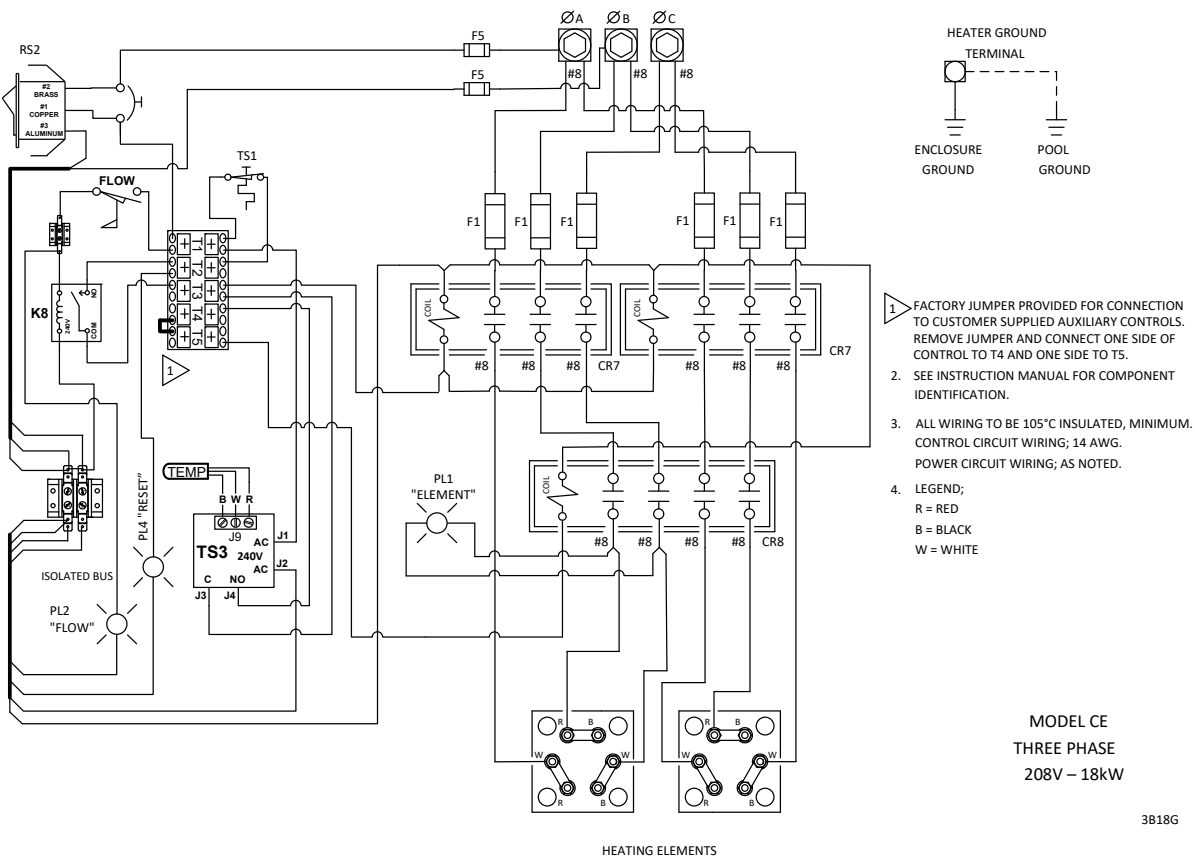
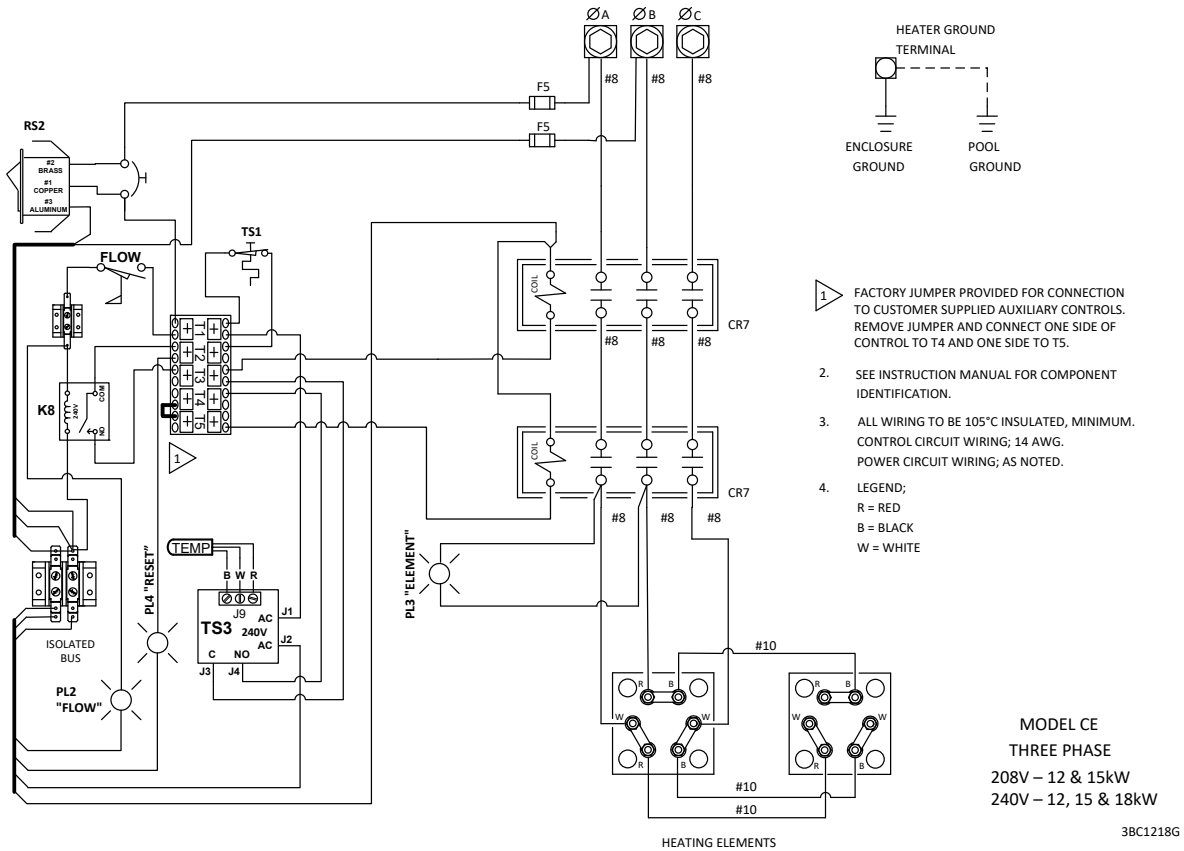

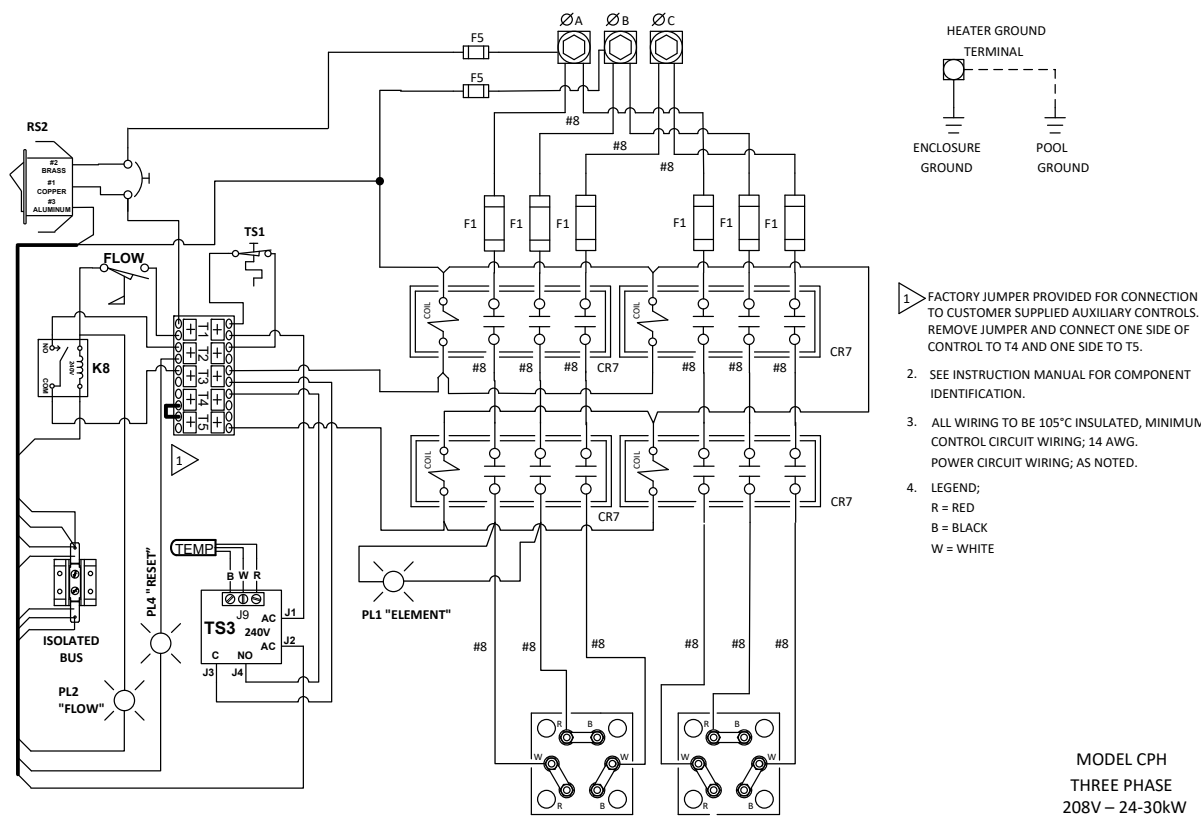

1. FACTORY JUMPER PROVIDED FOR CONNECTION TO CUSTOMER SUPPLIED AUXILIARY CONTROLS. REMOVE JUMPER AND CONNECT ONE SIDE OF CONTROL TO T4 AND ONE SIDE TO T5.
2. SEE INSTRUCTION MANUAL FOR COMPONENT IDENTIFICATION.
3. ALL WIRING TO BE 105°C INSULATED, MINIMUM. CONTROL CIRCUIT WIRING; 14 AWG. POWER CIRCUIT WIRING; AS NOTED.
4. LEGEND;  
R = RED  
B = BLACK  
W = WHITE

MODEL CPH  
THREE PHASE  
208V – 24-30kW  
240V – 24-30kW

HEATING ELEMENTS

3BC2430K

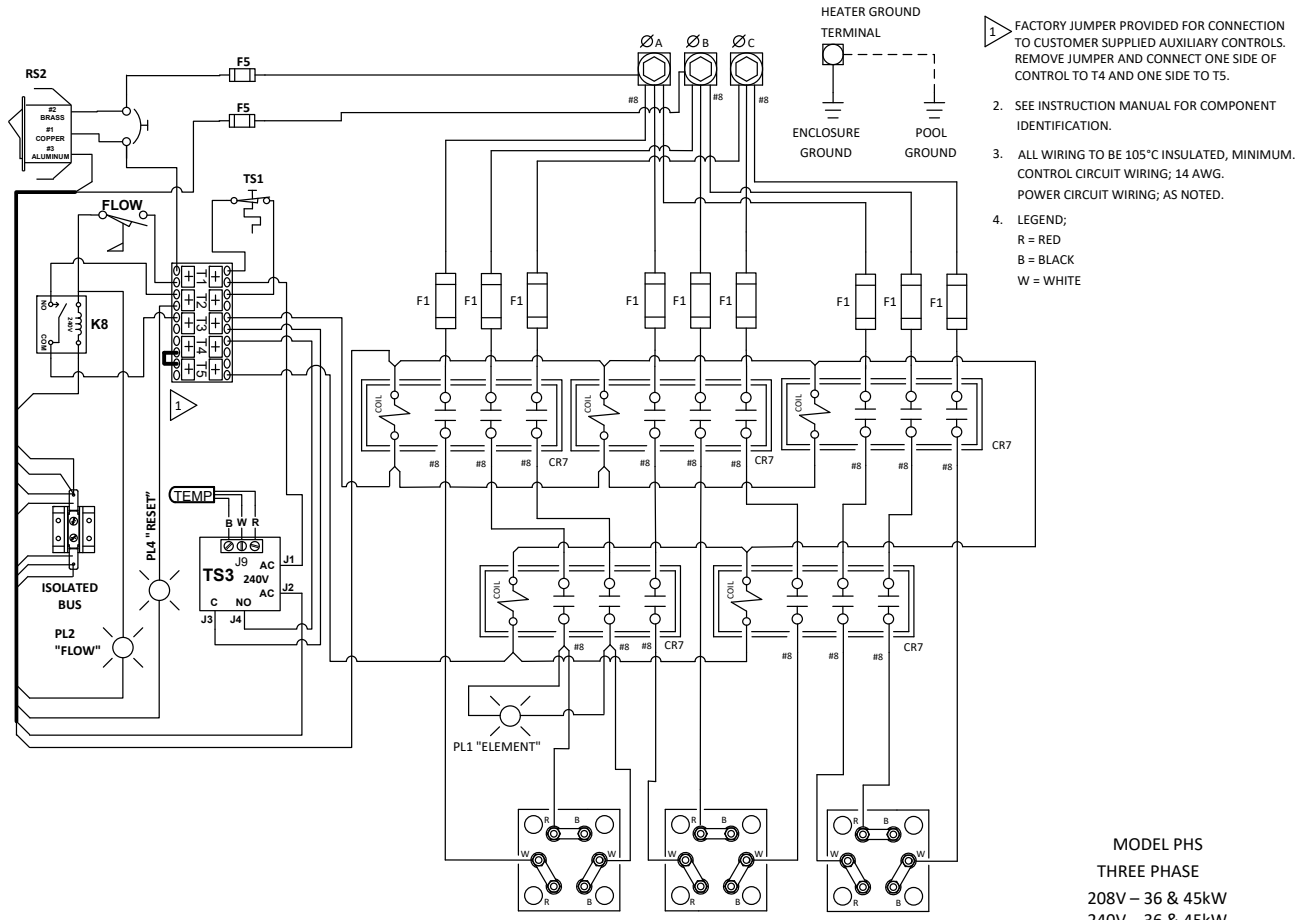

1. FACTORY JUMPER PROVIDED FOR CONNECTION TO CUSTOMER SUPPLIED AUXILIARY CONTROLS. REMOVE JUMPER AND CONNECT ONE SIDE OF CONTROL TO T4 AND ONE SIDE TO T5.
2. SEE INSTRUCTION MANUAL FOR COMPONENT IDENTIFICATION.
3. ALL WIRING TO BE 105°C INSULATED, MINIMUM. CONTROL CIRCUIT WIRING; 14 AWG. POWER CIRCUIT WIRING; AS NOTED.
4. LEGEND;  
R = RED  
B = BLACK  
W = WHITE

MODEL PHS  
THREE PHASE  
208V – 36 & 45kW  
240V – 36 & 45kW

HEATING ELEMENTS

3BC3645H

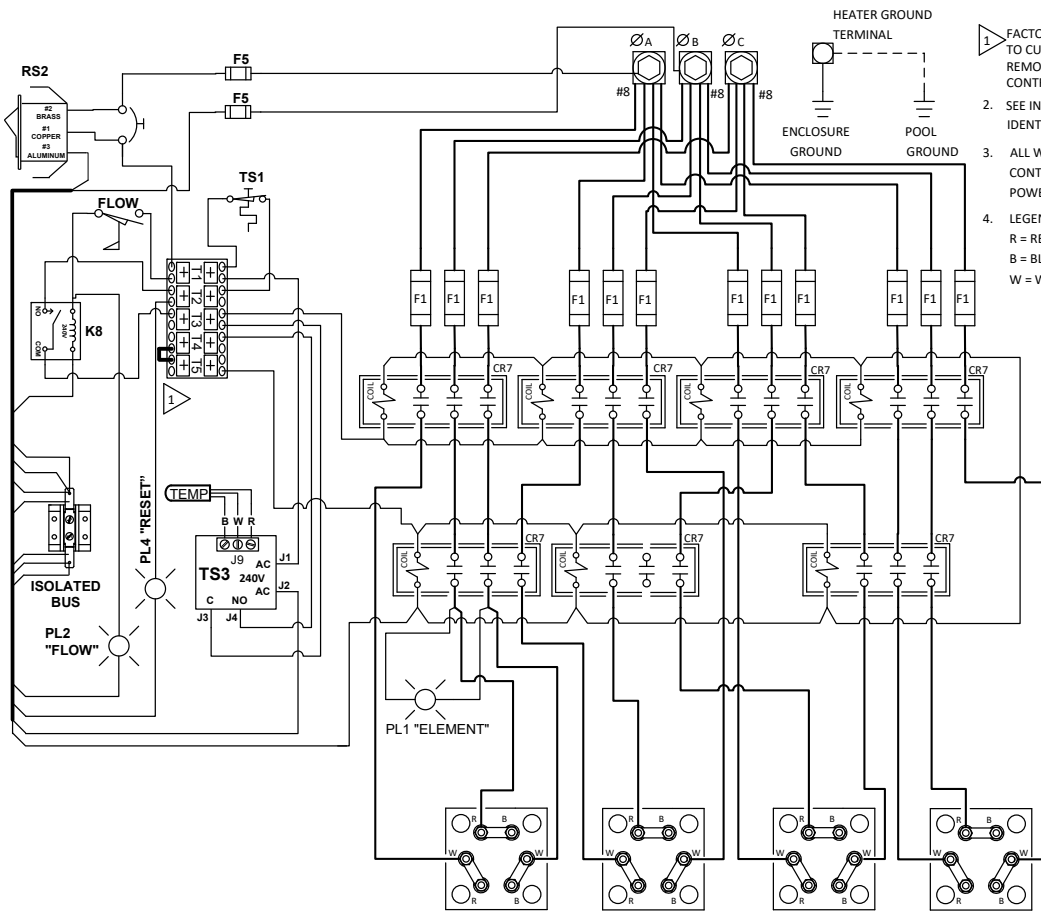

1. FACTORY JUMPER PROVIDED FOR CONNECTION TO CUSTOMER SUPPLIED AUXILIARY CONTROLS. REMOVE JUMPER AND CONNECT ONE SIDE OF CONTROL TO T4 AND ONE SIDE TO TS.
2. SEE INSTRUCTION MANUAL FOR COMPONENT IDENTIFICATION.
3. ALL WIRING TO BE 105°C INSULATED, MINIMUM. CONTROL CIRCUIT WIRING; 14 AWG. POWER CIRCUIT WIRING; AS NOTED.
4. LEGEND;  
R = RED  
B = BLACK  
W = WHITE

MODEL PHS  
THREE PHASE  
208V – 54 & 57kW  
240V – 54 & 57kW

HEATING ELEMENTS

3BC5457K

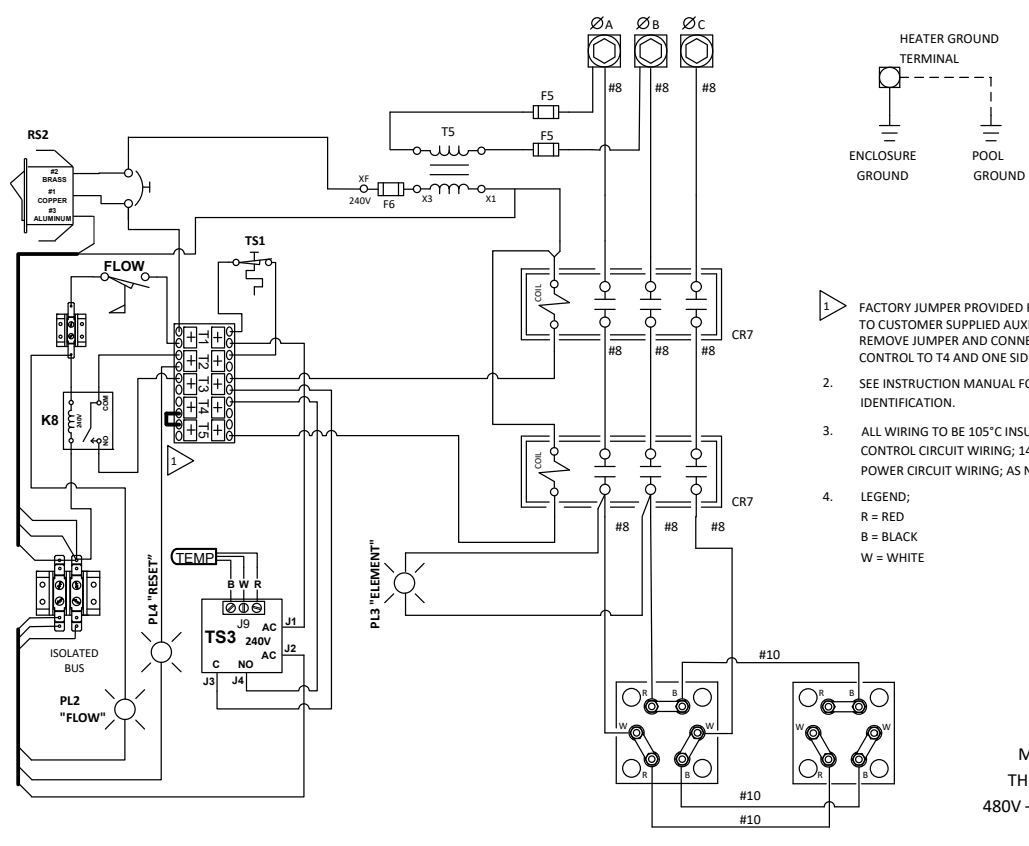

1. FACTORY JUMPER PROVIDED FOR CONNECTION TO CUSTOMER SUPPLIED AUXILIARY CONTROLS. REMOVE JUMPER AND CONNECT ONE SIDE OF CONTROL TO T4 AND ONE SIDE TO TS.
2. SEE INSTRUCTION MANUAL FOR COMPONENT IDENTIFICATION.
3. ALL WIRING TO BE 105°C INSULATED, MINIMUM. CONTROL CIRCUIT WIRING; 14 AWG. POWER CIRCUIT WIRING; AS NOTED.
4. LEGEND;  
R = RED  
B = BLACK  
W = WHITE

MODEL CE  
THREE PHASE  
480V – 12, 15 & 18kW

HEATING ELEMENTS

311218K

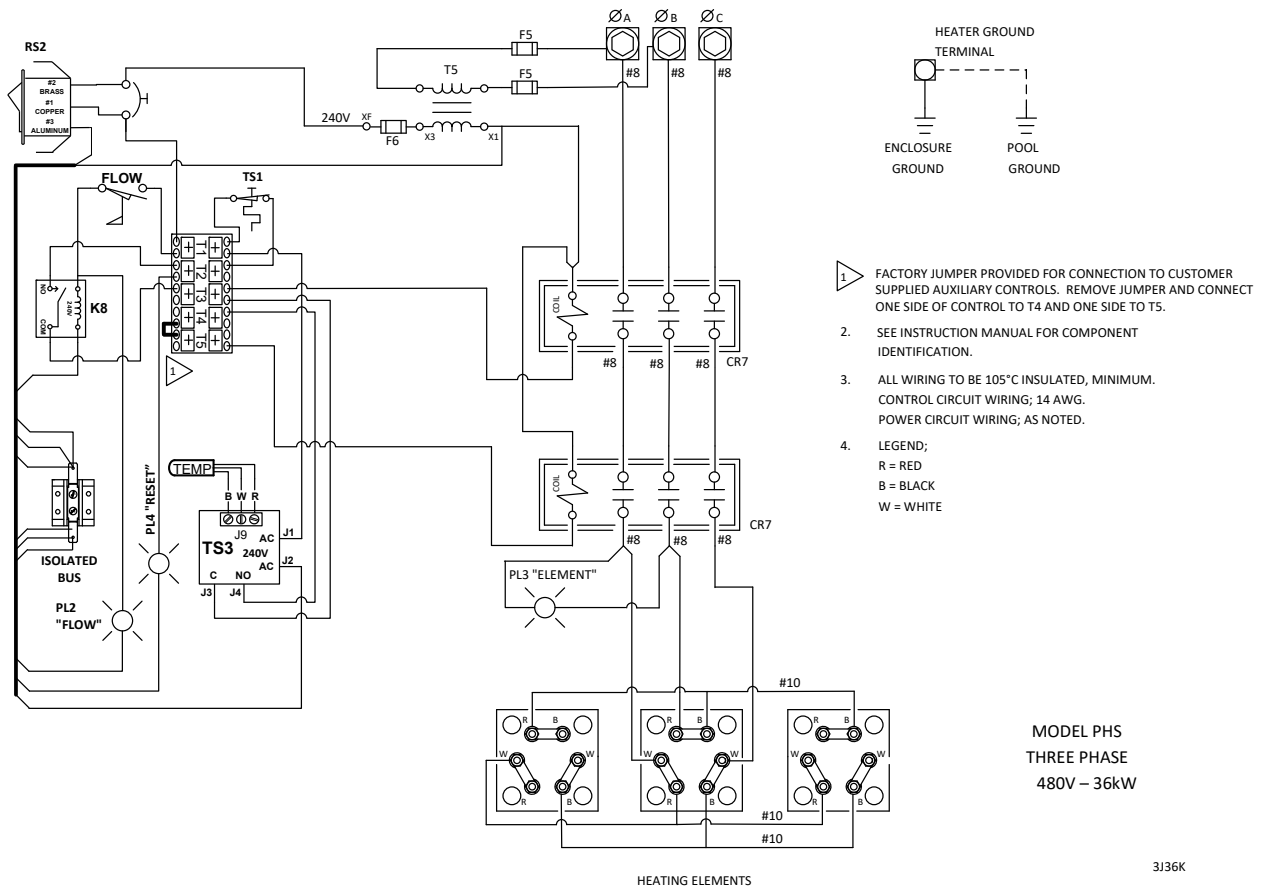
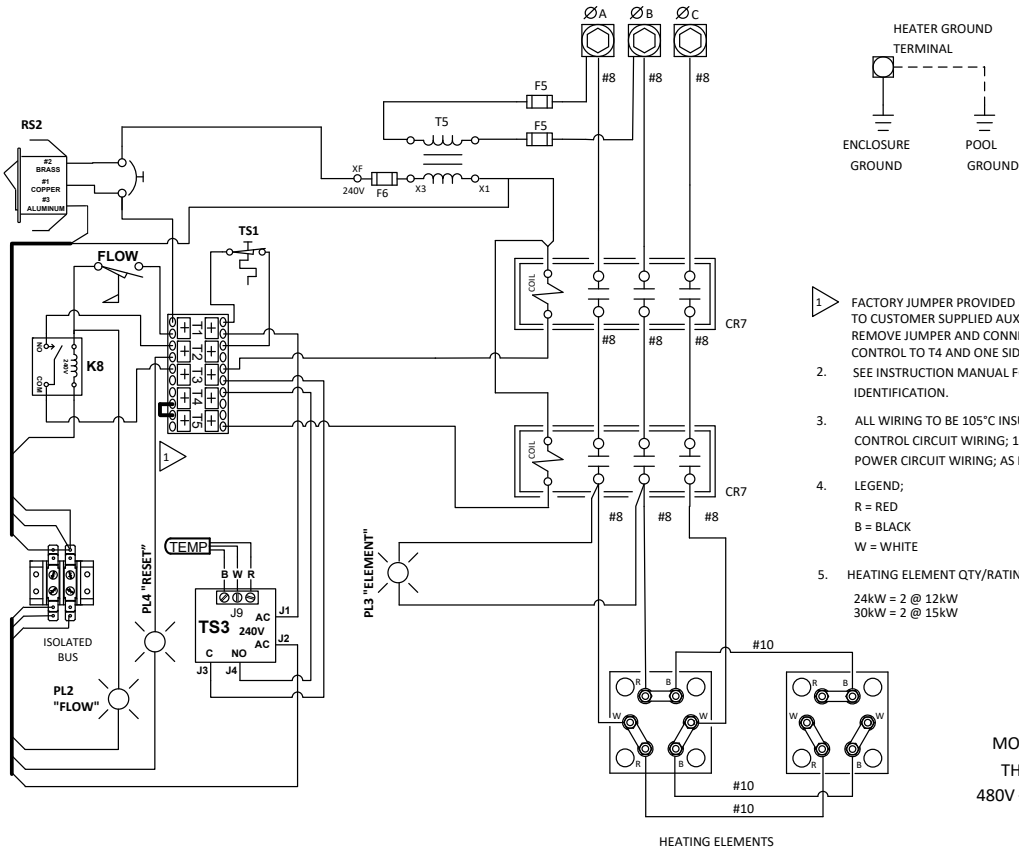

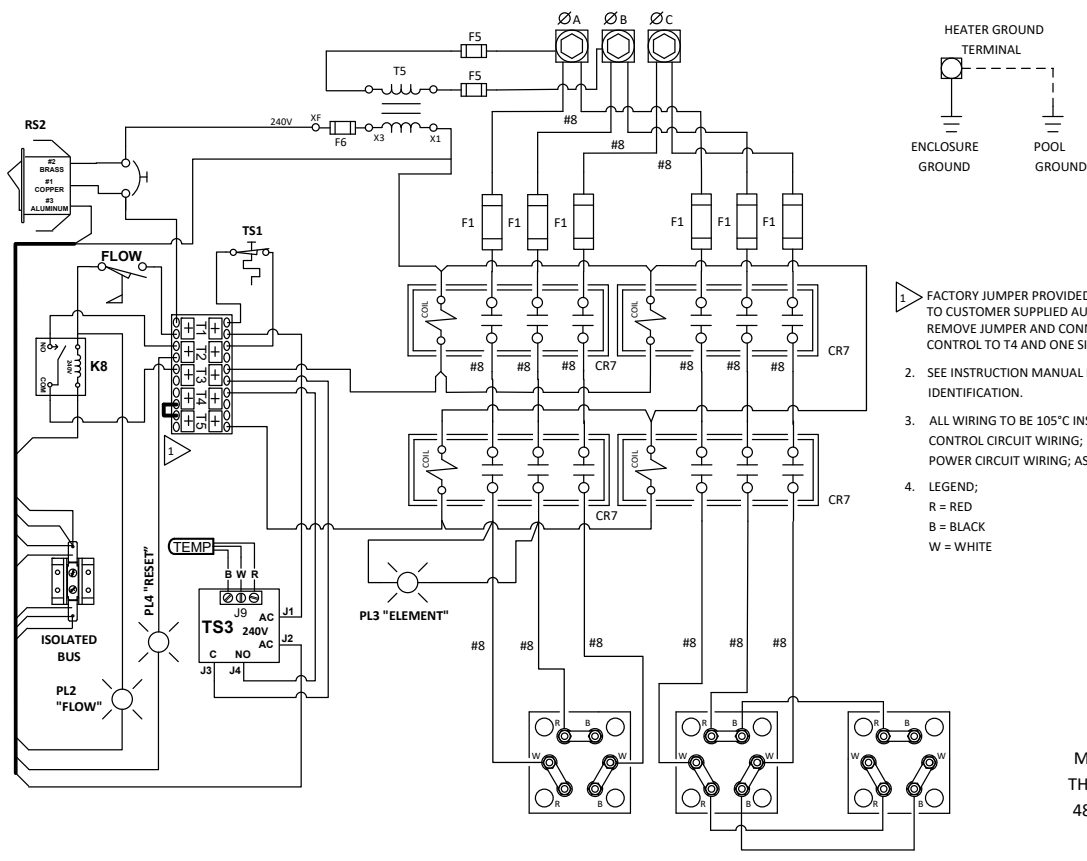

MODEL PHS  
THREE PHASE  
480V - 45kW

HEATING ELEMENTS

3J45K

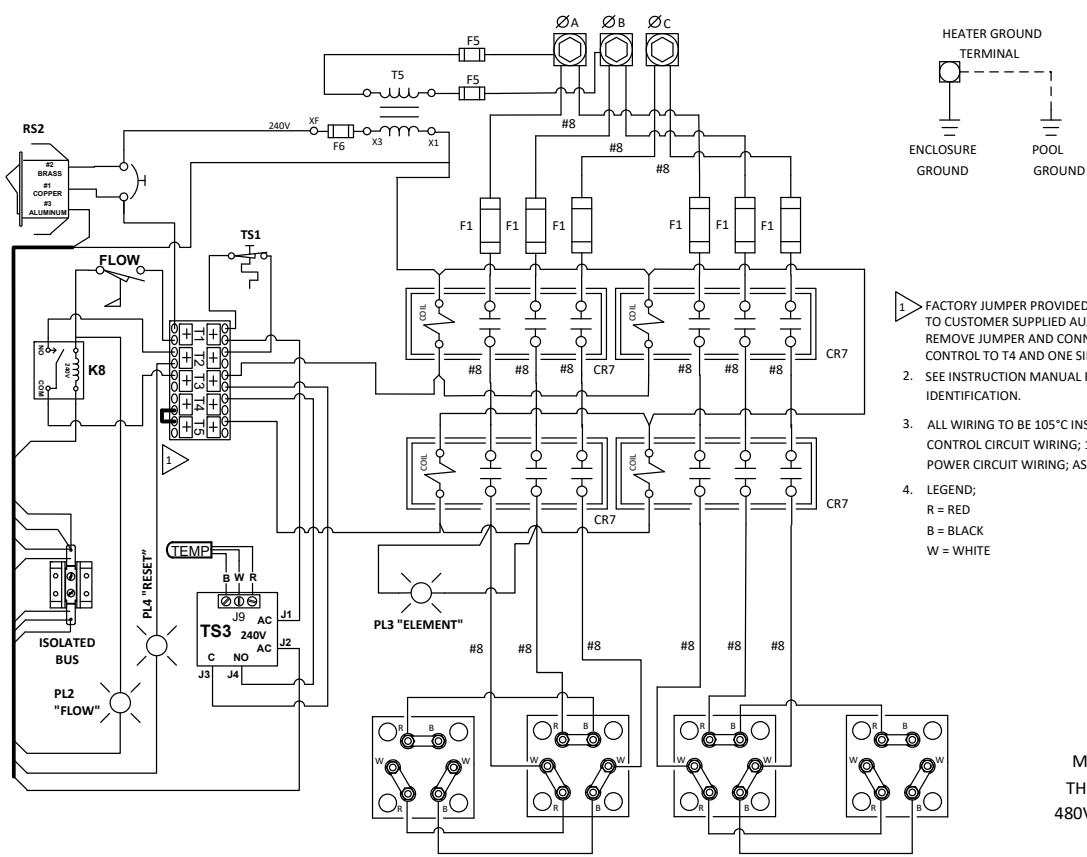

MODEL PHS  
THREE PHASE  
480V - 54 & 57kW

HEATING ELEMENTS

3J5457K

# LIMITED WARRANTY

The company extends this limited warranty to the original purchaser of a Coates Electric Pool Heater.

Coates warrants the electrical components\* and wiring (excluding enclosure, enclosure parts, knobs and accessories) in this new Pool Heater to be free from defects in materials and workmanship for one (1) year from the provable date of purchase, or eighteen (18) months from date of factory shipment, whichever occurs first. Coates further warrants the stainless steel water containment vessel to be free from defects in materials and workmanship for two (2) years from the provable date of purchase or thirty (30) months from the factory shipment, whichever occurs first. Enclosure, enclosure parts, knobs and accessories have no warranty whatsoever.

\*Exception: Factory installed heating elements are warranted for ninety 90 days from the date of heater installation, or eighteen (18) months from date of factory shipment, whichever occurs first.

COATES will repair or replace at its option, defective component parts as explained above, during the warranty period provided such parts are returned to the factory, freight prepaid. Factory authorization **MUST BE OBTAINED** under this warranty before returning such defective parts.

## Limited Warranty Does Not Cover

1. New products purchased outside the United States of America and Canada.
2. Uncrating, unpacking, set-up, installation and / or startup of this unit.
3. Adjustments to controls normally operated by consumer, purchaser or installer.
4. This limited warranty does not extend to any defect, malfunction or failure caused by, or resulting from improper service, maintenance or repair, abuse, neglect, accident, **corrosion caused by improper water chemistry or by equipment that use salt to create a sanitizer**, lack of water, or any other cause beyond the control of Coates Heater Company, Inc. or to any product where the nameplate shall have been removed, altered, replaced, defaced or rendered illegible.
5. This limited warranty is void if the Heater is used in a salt water system or under any extreme or unusual corrosive condition for which stainless steel metals would not be recommended.
6. This limited warranty does not extend to the repair or replacement of defective components except at COATES or a service facility authorized by COATES

IMPLIED WARRANTIES, WHEN APPLICABLE, SHALL COMMENCE UPON THE SAME DATE AS THE EXPRESS WARRANTY PROVIDED ABOVE, AND SHALL, EXCEPT FOR WARRANTIES OF TITLE, EXTEND ONLY FOR THE DURATION OF THE EXPRESS WARRANTY. SOME STATES DO NOT ALLOW LIMITATIONS ON HOW LONG AN IMPLIED WARRANTY LASTS, SO THE ABOVE LIMITATION MAY NOT APPLY TO YOU. THE ONLY REMEDY PROVIDED TO YOU UNDER AN APPLICABLE IMPLIED WARRANTY AND THE EXPRESS WARRANTY SHALL BE THE REMEDY PROVIDED UNDER THE EXPRESS WARRANTY, SUBJECT TO THE TERMS AND CONDITIONS CONTAINED THEREIN.

COATES SHALL NOT BE LIABLE FOR INCIDENTAL AND CONSEQUENTIAL LOSSES AND DAMAGES, UNDER THE EXPRESS WARRANTY, ANY APPLICABLE IMPLIED WARRANTY, OR CLAIMS FOR NEGLIGENCE, EXCEPT TO THE EXTENT THAT THIS LIMITATION IS FOUND TO BE UNENFORCEABLE UNDER APPLICABLE STATE LAW.

SOME STATES DO NOT ALLOW THE EXCLUSION OF LIMITATION OF INCIDENTAL OR CONSEQUENTIAL DAMAGES, SO THE ABOVE LIMITATION OR EXCLUSION MAY NOT APPLY TO YOU.

THIS WARRANTY GIVES YOU SPECIFIC LEGAL RIGHTS, AND YOU MAY ALSO HAVE OTHER RIGHTS WHICH VARY FROM STATE TO STATE.



HEATER COMPANY, INC.

P.O. Box 1750  
Kent, WA 98035