



SPA HEATER

INSTALLATION, OPERATION AND MAINTENANCE

MODELS:

ST SERIES
5.5 & 11kW
240V SINGLE PHASE

BEFORE YOU BEGIN

CHECK ALL ELECTRICAL CONNECTIONS TO ALL COMPONENTS WITHIN THE HEATER FOR TIGHTNESS. CONNECTIONS CAN BECOME LOOSE DURING SHIPMENT AND HANDLING.

CAUTION

THE ELECTRICAL INSTALLATION MUST BE IN ACCORDANCE WITH ARTICLE 680 OF THE NATIONAL ELECTRICAL CODE.

WARNING

Only qualified personnel, as defined by National Electric Code Article 100, should install and maintain this equipment. Unauthorized alteration or improper maintenance of this unit may release the manufacturer from any warranty claims. The installation must be in accordance with the instructions in this manual and applicable local plumbing and electrical codes.

1.0 DESCRIPTION

Coates Spa Heaters are intended for use on spas or hot tubs having a forced water circulation system.

The water flow through the heater should be at least 15 GPM but should not exceed 80 GPM. Higher flow may damage the heater. An external bypass should be installed to limit the flow to within this range.

2.0 INSTALLATION

WARNING

Only qualified personnel, as defined by National Electric Code Article 100, should install and maintain this equipment. Unauthorized alteration or improper maintenance of this unit may release the manufacturer from any warranty claims. The installation must be in accordance with the instructions in this manual and applicable local plumbing and electrical codes.

CHECK ELECTRICAL CONNECTIONS TO ALL COMPONENTS within the heater for tightness. These can become loose during shipment and handling.

2.1 PHYSICAL PLACEMENT

The Coates Spa Heater is suitable for indoor or outdoor installation. See Figure 1 for piping connections and Figures 3A or 3B for electrical connections. The heater should be securely mounted to a smooth, flat surface. It may be conveniently located next to the filtration equipment. **Leave minimum clearances of 9 inches on the left for element removal, 12 inches on the front for maintenance, 6 inches on the back for service entrance and the right side will be determined by the plumbing configuration used.**

2.2 ELECTRICAL INSTALLATION

The electrical supply power must be single phase,

CAUTION

THE ELECTRICAL INSTALLATION MUST BE IN ACCORDANCE WITH ARTICLE 680 OF THE NATIONAL ELECTRICAL CODE (NEC).

2 wire, 240 VAC. The supply must be protected by a ground fault circuit interrupter (GFCI) in accordance with NEC Article 680. An electrical disconnect with over-current protection must be provided. An insulated ground conductor must be provided. See Figures 3A or 3B and Table 1 for supply wire and circuit sizing. A lug has been provided for attachment of the BONDING wire per the NEC Article 680-22, (a)(4). This lug is located between the inlet and outlet pipes of the heater

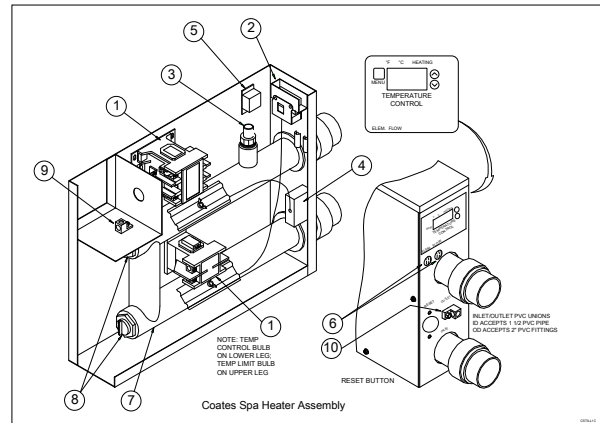

Figure 2 – Coates Spa Heater Assembly.
Refer to Table 2 for part description.

** NOTICE **

NO PRESSURE RELIEF VALVE IS SHIPPED WITH THIS HEATER AND NONE IS REQUIRED PER UL STD 1261. DO NOT INSTALL SHUT OFF VALVE BETWEEN THE HEATER AND POOL OR SPA. A CHECK VALVE IS ACCEPTABLE AND IN ACCORDANCE TO UL STD 1261 REVISED JULY 1983.

CAUTION
DO NOT INSTALL ANY SHUT-OFF VALVE ON DISCHARGE SIDE OF HEATER. A SWING CHECK VALVE IS PERMITTED.

Exception: If a 30 psi (2.1 Kg/cm²) pressure relief valve is installed between the heater and valve, the valve may be of the shut-off (ball or gate) type.

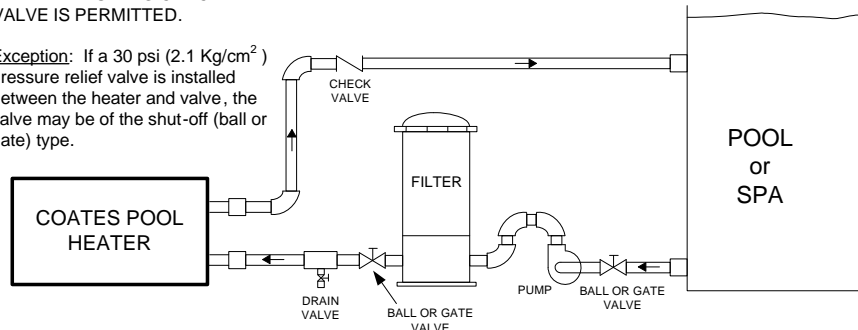

FIGURE 1 – PIPING DIAGRAM

3.0 CONTROL PANEL

A. INDICATOR LIGHTS

The control has two indicator lights. The lights are as follows:

STATUS LIGHTS	
LIGHT	DESCRIPTION (when Illuminated)
FLOW	Sufficient water flow through heater.
ELEMENT	Heating elements are powered.

B. DIGITAL THERMOSTAT CONTROL

For heaters equipped with a digital thermostat. The digital thermostat control which measures the temperature of the water as it enters the heater has a MENU button, up and down adjustment buttons, and an LED display. The desired water temperature (set point) is controllable between 40°F and 104°F (5°C and 40°C). The set point may differ from the actual water temperature at the pool or spa due to heat loss in the piping.

MENU:

The MENU button cycles through the three menu items: Measured Water Temperature (default), SET POINT and °F/°C.

ADJUSTING THE SET POINT:

Press one of the following buttons; MENU, ⤴ or ⤵. The display will momentarily blank and then the current set point will be displayed. Press the ⤴ or ⤵ button to change the set point. Hold the button down for rapid temperature changes.

The set point will be saved and the display will return to the measured temperature after two seconds of inactivity.

OPERATION:

In the measured temperature mode, the water temperature in the heater is displayed. The LED corresponding to the current temperature scale will be illuminated. If the heater is calling for heat the HEATING LED will be illuminated.

FAHRENHEIT TO CELCIUS:

Press the MENU button twice and the current temperature scale will be displayed (F or C). Press the ⤴ or ⤵ buttons to toggle between F and C.

The temperature scale will be saved and the display will return to the measured temperature after two seconds of inactivity.

ERROR CODE:

The display will read “Err” when it detects a problem with the temperature sensor. This can be caused by a faulty sensor or a loose connection between the sensor and the temperature controller.

3.1 CAUTIONS AND WARNINGS

1. Be sure to check all cautions and warnings in this manual and as displayed on the heater labels before operating or performing and maintenance on these heaters.
2. Do not remove the heater cover while electrical power is applied to the heater. Power must be interrupted at the heater supply circuit breaker or disconnect switch.
3. The MIN setting on the temperature control dial is an OFF position. The heater will not operate at this setting regardless of water temperature.

3.2 STARTING THE HEATER

- CAUTION -

Do not operate heater without water.

1. Ensure that heater case is properly grounded, and bonded.
2. Fill the system with water and start the circulating pump.
3. Turn on electrical power at the heater supply circuit breaker.
4. Set the temperature control to desired water temperature and adjust accordingly after the temperature has stabilized. DO NOT EXCEED 104°F.

3.3 STOPPING THE HEATER

Turn off electrical power at the heater supply circuit breaker before stopping the circulating pump.

4.0 MAINTENANCE

1. Keep the heater clean.
2. If high temperature causes the limit thermostat to cut off the electrical power, turn off power at disconnect switch and determine the cause before resetting the switch. A water temperature drop is required to allow resetting of the manual reset high temperature limit.
3. If leaks develop in the heater or connecting piping, shut down the heater and repair defective connections.
4. If heating elements are removed for replacement, use only Coates elements, see Table 2.

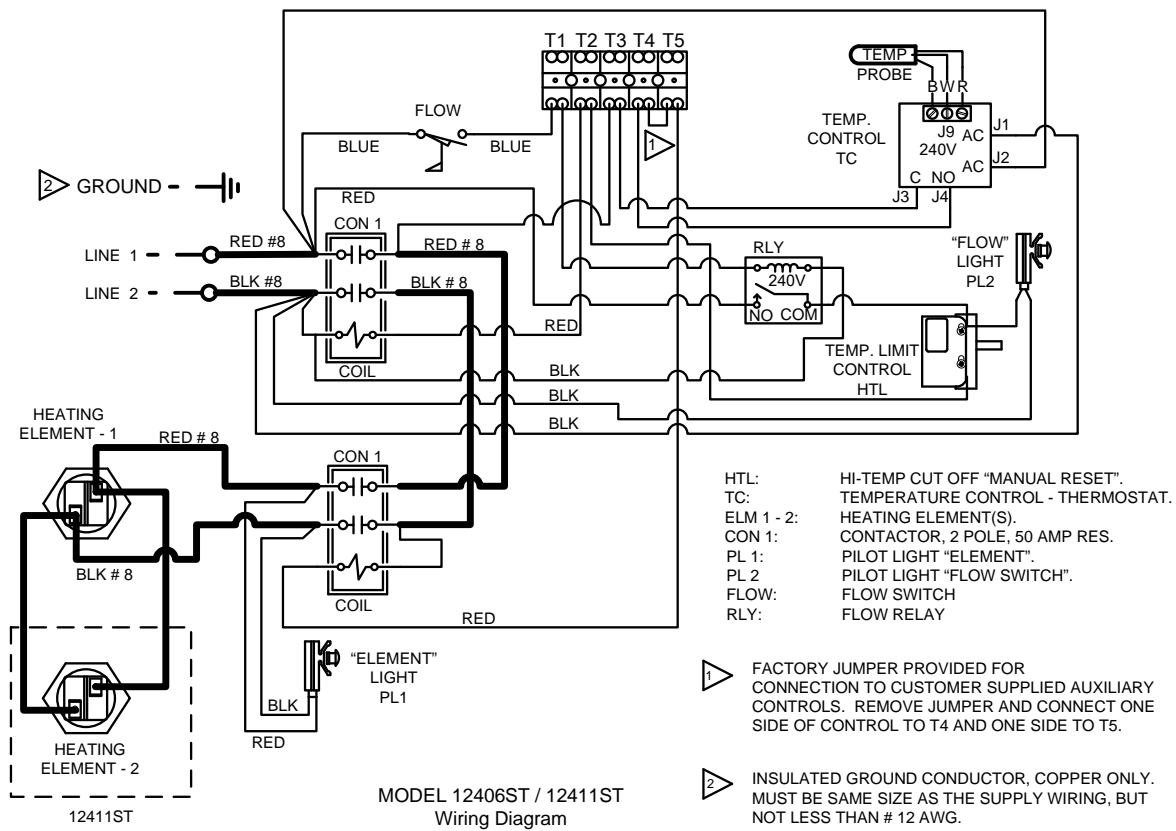

TABLE 1

MODEL NO.	HEATER KW/VOLT RATING	NO. & KW OF HEATING ELEMENTS	HEATER CURRENT RATING	RECOMMENDED CIRCUIT RATING	RECOMMENDED SUPPLY WIRING
					COPPER @ 60° C
12406ST	5.5 @ 240VAC	1 @ 5.5 KW	23 AMPS	30 AMPS	#10 AWG
12411ST	11 @ 240 VAC	2 @ 5.5 KW	46 AMPS	60 AMPS	#4 AWG

TABLE 2

ITEM	PART NUMBER	DESCRIPTION	QTY
1 - CON1	21000100	CONTACTOR, 2P, 50 AMP, 240VAC	2
2 - TC	22002150	DIGITAL TEMPERATURE CONTROL	1
3 - FLOW	23000105	FLOW SWITCH, 20 GPM	1
4 - HTL	22003820	HIGH TEMPERATURE LIMIT, MANUAL RESET	1
5 - RLY	21006010	FLOW RELAY, 30AMP, 240V	1
6 - PL1,2	29034620	PILOT LIGHTS for ELEMENT and FLOW	2
7	62002620	VESSEL ASSEMBLY, STAINLESS STEEL	1
8	20005061	HEATING ELEMENT, 5.5KW, 240 VOLTS	*
9	29020025	GROUND LUG, LA-2	1
10	29020035	BONDING LUG, SAU-70	1
11	32705010	UNION ASSEMBLY	2

* SEE TABLE 1 FOR ELEMENT QUANTITY

When ordering parts from your dealer, provide the model number and serial number of your heater.

WARNING:
Only qualified personnel should attempt maintenance on this equipment. (NEC Article 100)

HEATER TROUBLE SHOOTING GUIDE

- CAUTION -

This heater incorporates 240 volt electrical circuits.
 Do not open the case unless unit is disconnected from electrical power.
 Use only manufacturer's parts, or UL listing and warranty may be void.

PROBLEM	INDICATORS	POSSIBLE CAUSES	ACTION
No Heat	No lights ON	No Power to heater	Check Circuit Breaker "ON".
		Insufficient Flow	Check that pump is running and filter is clean.
		Flow Switch Inoperative	Use Ohm meter to check continuity across switch while pump is running. Replace Flow Switch if Open.
		Flow Relay Inoperative	Use Ohm meter to check continuity across NO and COM terminals while pump is running. Replace Flow Switch if Open.
	Flow light ON Element light OFF	Hi-Limit Reset Tripped	Push "Reset" button
		High Limit switch inoperative	Use Ohm meter to check continuity across switch. Replace High Limit Switch if always open.
		Temp Control inoperative or set too low	Adjust control higher or replace as required. Check "HEATING" indicator light on temp display is "ON"
		Contactors (upper) inoperative	Replace upper contactor
Flow light ON Element light ON	Contactors (lower) inoperative	Replace lower contactor	
	Heating Element(s) inoperative	Replace Element(s) as required.	
Insufficient Heat	Flow light ON	Heater too small for Spa	Check heater sizing requirement of Spa.
	Element light ON	One element inoperative on 11KW model	Replace Element as required.
High Limit RESET Trips	Flow light ON Element light OFF	Temperature control inoperative, water overheats in Spa.	Replace Temperature Control.
		Flow Switch not turning off heater when pump/flow stops	Check flow switch opens when pump is off. Replace as required.
		Heater subjected to high ambient temperature (i.e. Direct sunlight)	Cool Equipment room or shade heater from sun.
		High Limit switch inoperative	Replace High Limit Switch
Water Temp Greater than setpoint	Flow light ON Element light ON	Thermostat out of calibration/inoperative	Replace thermostat.
	Flow light ON Element light OFF	External heat source (i.e. Solar Heating, heat from the pump, etc.)	Turn off power to heater and verify problem continues.

Elements can be checked with an Ohm meter only when power is disconnected from heater and all wires have been removed from the element terminals. Each element should read approximately 10.5 Ohms.

Ambient temperatures above 120°F will cause the high temperature limit to trip prematurely.

PROTECTING YOUR COATES HEATER WITH PROPER WATER CHEMISTRY

Proper water balance is important to extending the life of your Coates Heater. While pH control is critical, the control of alkalinity and calcium hardness will protect against scaling and also help to prevent corrosion.

	ACID							ALKALINE								
HEATER CAN BE DAMAGED	CORROSIVE WATER							IDEAL RANGE	ALKALINE WATER							HEATER CAN BE DAMAGED
	0	1	2	3	4	5	6		7	8	9	10	11	12	13	

The correct level of sanitizer, pH, total alkalinity and calcium hardness will vary, depending on the type of pool (plaster, fiberglass or vinyl) and the chemical content of the fill water. Water that is out of balance can damage your pool heater and void the warranty. This heater is not for use in salt water pools.

IMPORTANT SAFETY INSTRUCTIONS

When using this electrical equipment, basic safety precautions should always be followed, including the following.

1) READ AND FOLLOW ALL INSTRUCTIONS.

2) To reduce the risk of injury.

- A) The water in a pool or tub should never exceed 104°F (40°C). A water temperature in excess of 104°F is considered unsafe for all persons. Lower water temperatures are recommended for extended use (exceeding 10-15 minutes) and for young children. SEE "STARTING THE HEATER" IN THE OPERATIONS & MAINTENANCE MANUAL FOR INSTRUCTIONS ON HOW TO ADJUST THE TEMPERATURE CONTROL.
- B) Since excessive water temperatures have a high potential for causing fetal damage during the early months of pregnancy, pregnant or possibly pregnant women should limit pool or tub water temperatures to 100°F (38°C).
- C) Before entering a pool or tub, the user should measure the water temperature at several occupant locations using an accurate thermometer since the tolerance of water temperature-regulating devices may vary as much as $\pm 5^\circ\text{F}$ ($\pm 3^\circ\text{C}$).
- D) Alcohol, drugs or medications should not be used before or during pool or tub use since their use may lead to unconsciousness with the possibility of drowning.
- E) Obese persons and persons with a medical history of heart disease, low or high blood pressure, circulatory system problems, or diabetes should consult a physician before using a pool or tub.
- F) Persons using medication should consult a physician before using a pool or tub since some medication may induce drowsiness while other medication may affect heart rate, blood pressure, and circulation.

3) SAVE THESE INSTRUCTIONS.

---WARNING--- DANGER OF HYPERTHERMIA

Hyperthermia occurs when the internal temperature of the body reaches a level several degrees above the normal body temperature of 98.6°F. The symptoms of hyperthermia include dizziness, fainting, drowsiness, lethargy and an increase in the internal temperature of the body. The effects of hyperthermia include:

- a) Unawareness of impending hazard;
- b) Failure to perceive heat;
- c) Failure to recognize the need to exit pool or tub;
- d) Physical inability to exit pool or tub;
- e) Fetal damage in pregnant women;
- f) Unconsciousness resulting in a danger of drowning.

WARNING--- The use of alcohol, drugs or medications can greatly increase the risk of fatal hyperthermia in pools and tubs.

**THIS PAGE
INTENTIONALLY
LEFT BLANK**

LIMITED WARRANTY

The company extends this limited warranty to the original purchaser of a Coates Electric Spa Heater.

Coates warrants the electrical components* and wiring (excluding enclosure, enclosure parts, knobs and accessories) in this new Spa Heater to be free from defects in materials and workmanship for one (1) year from the provable date of purchase, or eighteen (18) months from date of factory shipment, whichever occurs first. Coates further warrants the stainless steel water containment vessel to be free from defects in materials and workmanship for two (2) years from the provable date of purchase or thirty (30) months from the factory shipment, whichever occurs first. Enclosure, enclosure parts, knobs and accessories have no warranty whatsoever.

*Exception: Factory installed heating elements are warranted for ninety (90) days from the date of heater installation, or one (1) year from date of factory shipment, whichever occurs first.

COATES will repair or replace at its option, defective component parts as explained above, during the warranty period provided such parts are returned to the factory, freight prepaid. Factory authorization **MUST BE OBTAINED** under this warranty before returning such defective parts.

Limited Warranty Does Not Cover

1. New products purchased outside the United States of America and Canada.
2. Uncrating, unpacking, set-up, installation and / or startup of this unit.
3. Adjustments to controls normally operated by consumer, purchaser or installer.
4. This limited warranty does not extend to any defect, malfunction or failure caused by, or resulting from improper service, maintenance or repair, abuse, neglect, accident, **corrosion caused by improper water chemistry or by equipment that use salt to create a sanitizer**, lack of water, or any other cause beyond the control of Coates Heater Company, Inc. or to any product where the nameplate shall have been removed, altered, replaced, defaced or rendered illegible.
5. This limited warranty is void if the Heater is used in a salt water system or under any extreme or unusual corrosive condition for which stainless steel metals would not be recommended.
6. This limited warranty does not extend to the repair or replacement of defective components except at COATES or a service facility authorized by COATES

IMPLIED WARRANTIES, WHEN APPLICABLE, SHALL COMMENCE UPON THE SAME DATE AS THE EXPRESS WARRANTY PROVIDED ABOVE, AND SHALL, EXCEPT FOR WARRANTIES OF TITLE, EXTEND ONLY FOR THE DURATION OF THE EXPRESS WARRANTY. SOME STATES DO NOT ALLOW LIMITATIONS ON HOW LONG AN IMPLIED WARRANTY LASTS, SO THE ABOVE LIMITATION MAY NOT APPLY TO YOU. THE ONLY REMEDY PROVIDED TO YOU UNDER AN APPLICABLE IMPLIED WARRANTY AND THE EXPRESS WARRANTY SHALL BE THE REMEDY PROVIDED UNDER THE EXPRESS WARRANTY, SUBJECT TO THE TERMS AND CONDITIONS CONTAINED THEREIN.

COATES SHALL NOT BE LIABLE FOR INCIDENTAL AND CONSEQUENTIAL LOSSES AND DAMAGES, UNDER THE EXPRESS WARRANTY, ANY APPLICABLE IMPLIED WARRANTY, OR CLAIMS FOR NEGLIGENCE, EXCEPT TO THE EXTENT THAT THIS LIMITATION IS FOUND TO BE UNENFORCEABLE UNDER APPLICABLE STATE LAW.

SOME STATES DO NOT ALLOW THE EXCLUSION OF LIMITATION OF INCIDENTAL OR CONSEQUENTIAL DAMAGES, SO THE ABOVE LIMITATION OR EXCLUSION MAY NOT APPLY TO YOU.

THIS WARRANTY GIVES YOU SPECIFIC LEGAL RIGHTS, AND YOU MAY ALSO HAVE OTHER RIGHTS WHICH VARY FROM STATE TO STATE.



HEATER COMPANY, INC.

P.O. Box 1750
Kent, WA 98035