

ST

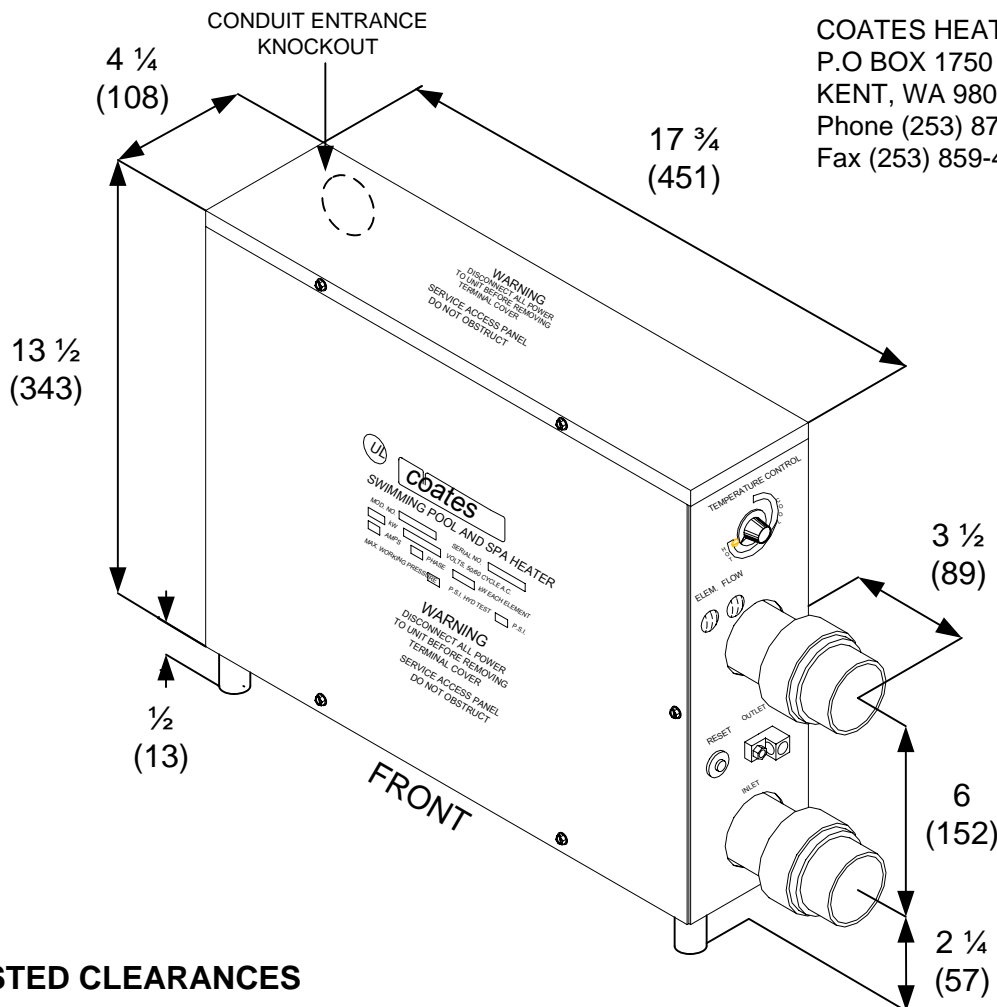

COATES HEATER CO. INC.
 P.O BOX 1750
 KENT, WA 98035
 Phone (253) 872-7256
 Fax (253) 859-4660



SUGGESTED CLEARANCES

Front	Back	Left	Right	Top
36**	4	10	*	24
(914)	(102)	(254)	*	(610)

Dimensions: Inches (mm)

*Required clearance is based on plumbing configuration used.

**Refer to NEC Table 110.26(A)(1)

MODEL	PHASE	VOLTS	KW	AMPS	BREAKER	WIRE/ 75°C	SHIP WT.
12004ST	1	208	4	20	25	#10	18 Lbs.
12008ST	1	208	8	39	50	#8	19 Lbs.
12406ST	1	240	5.5	23	30	#10	18 Lbs.
12411ST	1	240	11	46	60	#6	19 Lbs.

- MINIMUM FLOW RATE 15 GPM
- MAXIMUM FLOW RATE 80 GPM
- 1 1/2 X 2 INCH PVC UNION CONNECTIONS
- STAINLESS STEEL MANIFOLD
- INCOLOY HEATING ELEMENTS